

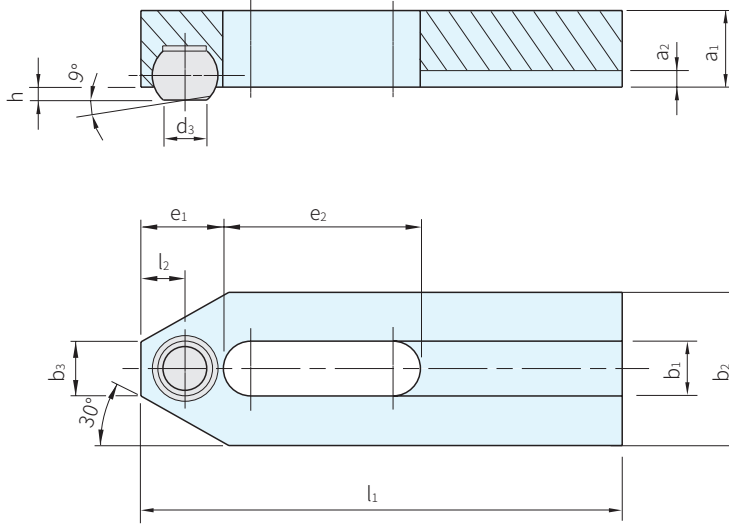

本體		珠子	
材質	處理	材質	處理
鋼	熱處理+染黑	SUJ2	硬化



品號	b ₁	l ₁	d ₃	a ₁	a ₂	b ₂	b ₃	e ₁	e ₂	h	l ₂	珠子 ∅	質量 g	庫存
23180.0007	6.6	50	5.8	10	2.5	20	8	10	20	1.6	5.0	8.5	61	△
23180.0009	9	60	7.2	12	3.0	25	10	13	22	2.0	6.5	10.0	109	△
23180.0011	11	80	8.6	15	3.5	30	12	15	30	2.7	7.5	12.0	218	△
23180.0014	13	125	10.5	20	4.0	40	14	21	50	3.5	10.5	16.0	618	△

SP. 特長

・ 珠子不翻轉

訂貨： 交期： 天
23180.0007

EX. 使用例

